



**INSTITUTO DE CIENCIAS
DE LA CONSTRUCCIÓN
EDUARDO TORROJA**

C/ Serrano Galvache n. 4 28033 Madrid (Spain)
Tel.: (34) 91 302 04 40 Fax: (34) 91 302 07 00
direccion.ietcc@csic.es <https://dit.ietcc.csic.es>

European Technical Assessment

ETA 19/0343 of 19/06/2019

English translation prepared by IETcc. Original version in Spanish language

General Part

Technical Assessment Body issuing the ETA designated according to Art. 29 of Regulation (EU) 305/2011

Instituto de Ciencias de la Construcción Eduardo Torroja (IETcc)

Trade name of the construction product

CLR 6

Product family to which the construction product belongs

Concrete screw of size 7.5 for use in cracked and non-cracked concrete.

Manufacturer

Friulsider S.p.A
Via Trieste,1
33048
S.Giovanni al Natisone (UD)
Italy

Manufacturing plants

Plant n.1

This European Technical Assessment contains

15 pages including 4 annexes which form an integral part of this assessment.

This European Technical Assessment is issued in accordance with regulation (EU) No 305/2011, on the basis of

European Technical Assessment EAD 330232-00-0601 "Mechanical Fasteners for use in concrete", ed. October 2016

This version replaces

-

English translation prepared by IETcc

This European Technical Assessment is issued by the Technical Assessment Body in its official language. Translations of this European Technical Assessment in other languages shall fully correspond to the original issued document and should be identified as such.

This European Technical Assessment may be withdrawn by the issuing Technical Assessment Body, in particular pursuant to information by the Commission according to article 25 (3) of Regulation (EU) No 305/2011.

English translation prepared by IETcc

SPECIFIC PART

1. Technical description of the product

The CLR 6 concrete screw is an anchor made of carbon steel. The anchor is made in size 7.5, and is screwed into a predrilled cylindrical drill hole. The special thread of the anchor cuts an internal thread into the member while setting. The anchorage is characterised by mechanical interlock in the special thread.

Product and product description is given in annex A.

2. Specification of the intended use in accordance with the applicable European Assessment Document.

The performances given in section 3 are only valid if the anchor is used in compliance with the specifications and conditions given in annex B.

The verifications and assessment methods on which this European Technical Assessment is based lead to the assumption of a working life of the anchor of at least 50 years. The indications given on the working life cannot be interpreted as a guarantee given by the producer, but are to be regarded only as a means to choosing the right products in relation to the expected economically reasonable working life of the works.

3. Performance of the product and references to the methods used for its assessment

3.1 Mechanical resistance and stability (BWR 1)

Essential characteristic	Performance
CLR 6 performance for static or quasi static actions	See annex C

3.2 Safety in case of fire (BWR 2)

Essential characteristic	Performance
Reaction to fire	Anchorage satisfy requirements for class A1
Resistance to fire	See annex D

4. Assessment and verification of constancy of performance (hereinafter AVCP) system applied, with reference to its legal base

The applicable European legal act for the system of Assessment and Verification of Constancy of Performances (see annex V of Regulation (EU) No 305/2011) is 96/582/EC.

The system to be applied is 1.

English translation prepared by IETcc

5. Technical details necessary for the implementation of the AVCP system, as provided for in the applicable European Assessment Document.

The technical details necessary for the implementation of the AVCP system are laid down in the quality plan deposited at Instituto de Ciencias de la Construcción Eduardo Torroja.



Instituto de Ciencias de la Construcción Eduardo Torroja
CONSEJO SUPERIOR DE INVESTIGACIONES CIENTÍFICAS

C/ Serrano Galvache n.º 4. 28033 Madrid.
Tel: (+34) 91 302 04 40 Fax. (+34) 91 302 07 00

<https://dit.ietcc.csic.es>



On behalf of the Instituto de Ciencias de la Construcción Eduardo Torroja
Madrid, 19th of June 2019



Director IETcc-CSIC

English translation prepared by IETcc

Product and identification

		SSW or LR-H
		SSR or LR-R
		SSP or LR-B
		SSK or LR-K
		SSH or LR-T
		SSX or LR-X
		SST or LR-P
		SSN or LR-Z

















CLR 6

Product description

Identification

Annex A1

English translation prepared by IETcc

		SSD or LR-D
		SSI or LR-U
		SSF or LR-F
		SSO or LR-E
		SSU or LR-C
		SSG or LR-G
		SSG2 or LR-I
		SSQ or LR-Q
		SSV or LR-V
CLR 6	Annex A2	
Product description		
Identification		

English translation prepared by IETcc

Marking/Identification on anchor:

- Company logo
- Outer diameter
- Length
- Anchor type:
 - CLR6-H: Hex head with washer SSW or LR-H
 - CLR6-R: Round head SSR or LR-R
 - CLR6-B: Button head SSP or LR-B
 - CLR6-K: Countersunk head SSK or LR-K
 - CLR6-T: Hex head SSH or LR-T
 - CLR6-X: Hex head, hexalobular recess SSX or LR-X
 - CLR6-P: Large head type P SST or LR-P
 - CLR6-Z: Large head type Z (with ribs) SSN or LR-Z
 - CLR6-D: Connection thread with hexagon drive SSD or LR-D
 - CLR6-U: Internal thread SSI or LR-U
 - CLR6-F: Flat washer head with connection thread SSF or LR-F
 - CLR6-E: Hex washer head with connection thread SSO or LR-E
 - CLR6-C: Hex head with connection thread SSU or LR-C
 - CLR6-G: Flex with coupler nut SSG or LR-G
 - CLR6-I: Flex with coupler nut without washer SSG2 or LR-I
 - CLR6-Q: Hex washer head flex with coupler nut SSQ or LR-Q
 - CLR6-V: Hex head flex with coupler nut SSV or LR-V

Table A1: Materials

Item	Designation	CLR 6
1	Anchor Body	Carbon steel wire rod cold forged. Allowed coatings: <ul style="list-style-type: none"> • Zinc plated ISO 4042 • Silver ruspert • Zinc flake EN 10683

CLR 6	Annex A3
Product description	
Identification	

English translation prepared by IETcc

Installed condition

- h_{ef} : Effective anchorage depth
- h_1 : Depth of drilled hole
- h_{nom} : Overall anchor embedment depth in the concrete
- h_{min} : Minimum thickness of concrete member
- t_{fix} : Thickness of fixture
- d_0 : Nominal diameter of drill bit
- d_f : Diameter of clearance hole in fixture

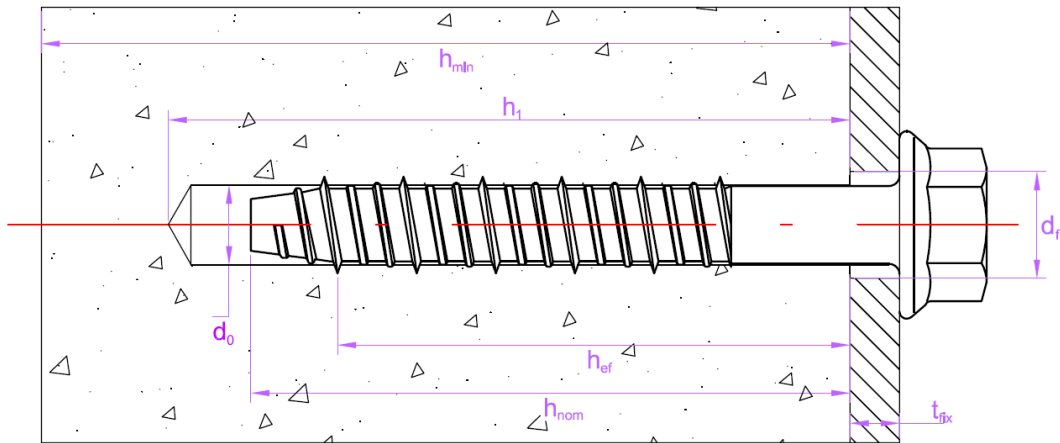

Drawing A1. Installed condition for anchors CLR6-H, CLR6-R, CLR6-B, CLR6-K, CLR6-T, CLR6-X, CLR6-P and CLR6-Z.

CLR 6	Annex A4
Product description	
Installed condition	

English translation prepared by IETcc

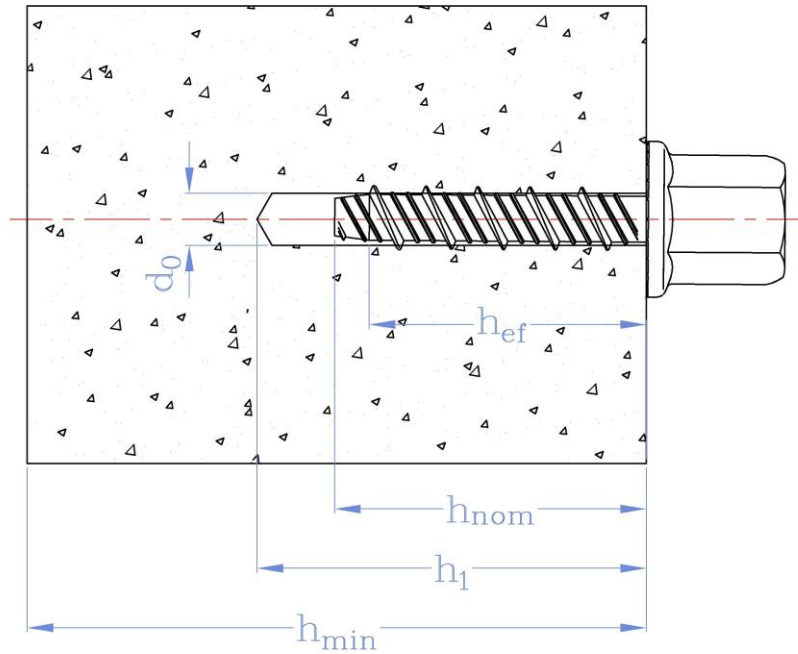

Drawing A2. Installed condition for anchors CLR6-D, CLR6-U, CLR6-F, CLR6-E, CLR6-C, CLR6-G, CLR6-I, CLR6-Q and CLR6-V.

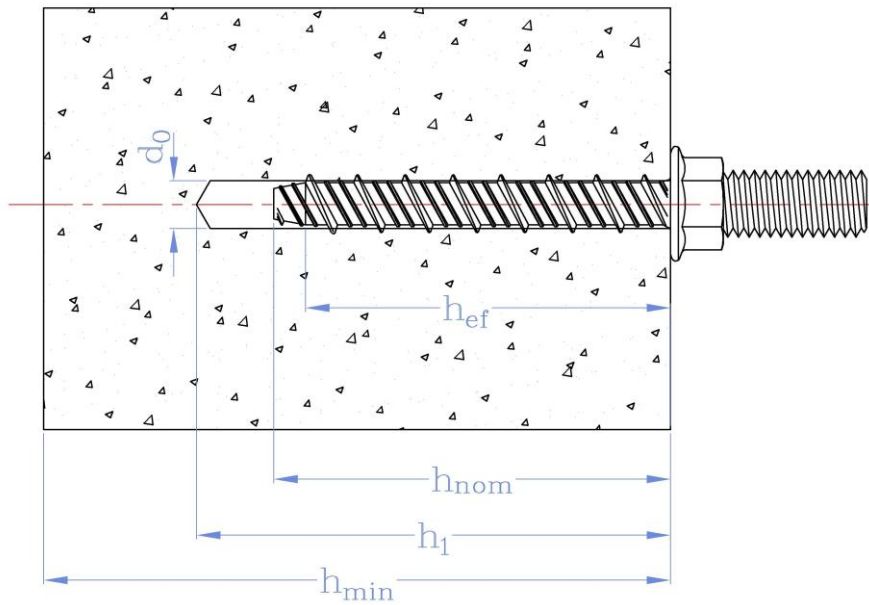

Drawing A3. Installed condition for anchors CLR6-D, CLR6-U, CLR6-F, CLR6-E, CLR6-C, CLR6-G, CLR6-I, CLR6-Q and CLR6-V.

<p>CLR 6</p>	<p>Annex A5</p>
<p>Product description</p>	
<p>Installed condition</p>	

Intended use

Anchorage subjected to:

- Static or quasi static loads: all sizes and embedment depths.

Base materials:

- Reinforced and unreinforced concrete according to EN 206-1.
- Strength classes C20/25 to C50/60 according to EN 206-1.
- Cracked and uncracked concrete.

Use conditions (environmental conditions):

- The anchor shall be used in dry internal conditions.
- The anchor may be used for anchorages with requirements related to resistance to fire.

Design:

- Anchorages are designed under the responsibility of an engineer experienced in anchorages and concrete.
- Verifiable calculation rules and drawings are prepared taking into account of the loads to be attached. The position of the anchor is indicated on the design drawings (e.g. position of the anchor relative to reinforcement or to supports, etc.)
- Anchorages under static or quasi-static loads are designed for design Method A in accordance with:
 - EN 1992-4:2018

Installation:

- Hammer drilling only.
- Anchor installation carried out by appropriately qualified personal and under the supervision of the person responsible for technical matters of the site.
- In case of aborted hole: new drilling at a minimum distance away of twice the depth of aborted hole or smaller distance if the aborted hole is filled with high strength mortar and if under shear or oblique tension load it is not the direction of the load application.
- After installation further turning of the anchor is not possible. The head of the anchor is supported on the fixture, as it is shown in Drawing B1, and it is not damaged.

CLR 6	Annex B1
Intended use Specifications	

Table B1: Installation parameters

Installation parameters			Performance
			CLR6
d_0	Nominal diameter of drill bit:	[mm]	6
d_f	Diameter of clearance hole in fixture:	[mm]	9
d_s	Outer diameter of the thread	[mm]	7.5
L_{min}	Total length of the anchor	[mm]	60
L_{max}		[mm]	400
h_{min}	Minimum thickness of concrete member:	[mm]	100
h_1	Depth of drilled hole:	[mm]	65
h_{nom}	Overall anchor embedment depth in the concrete:	[mm]	55
h_{ef}	Effective anchorage depth:	[mm]	42
T_{ins}	Installation torque	[Nm]	20
t_{fix}	Thickness of fixture	[mm]	L-55
s_{min}	Minimum allowable spacing:	[mm]	45
c_{min}	Minimum allowable edge distance:	[mm]	45

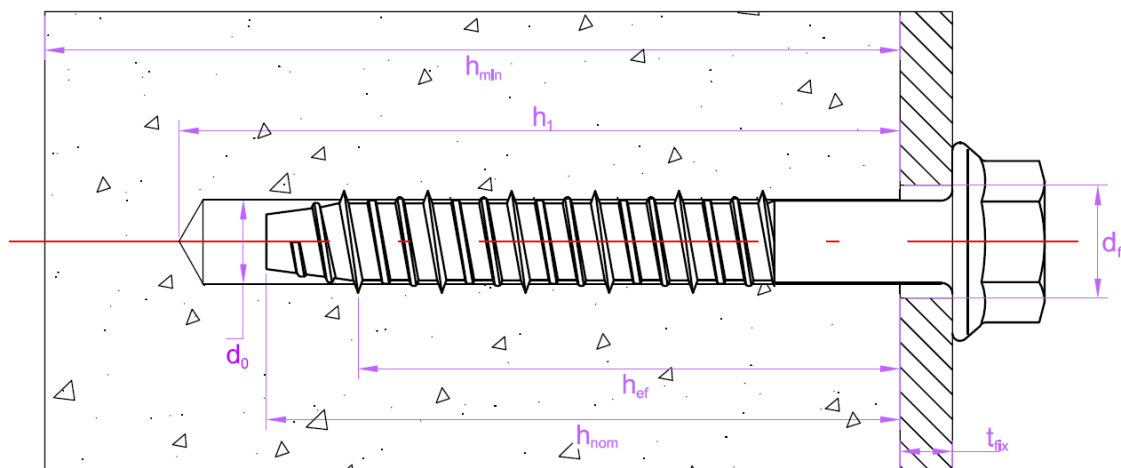

Drawing B1. Installed condition for anchors CLR6-H, CLR6-R, CLR6-B, CLR6-K, CLR6-T, CLR6-X, CLR6-P and CLR6-Z

Installation process

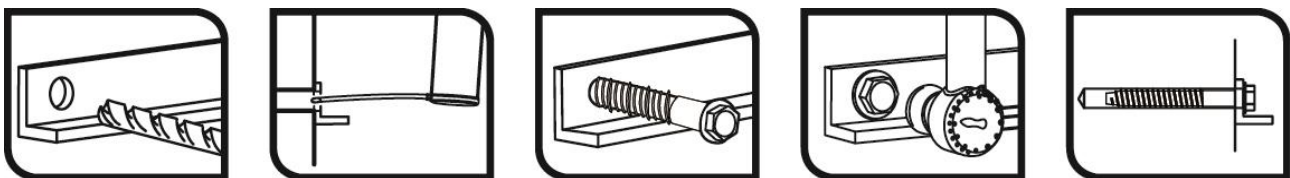

Anchor shall be installed using a torque wrench or an electrical impact driver; power input: 500 W; torque: 50-250 Nm. (e.g: Bosch GDS 18E)

CLR 6	Annex B2
Performances	
Installation parameters and installation procedure	

Table C1: Characteristic values to tension loads of design method A

Characteristic values of resistance to tension loads of design method A			Performance
			CLR6
Tension loads: steel failure			
$N_{Rk,s}$	Tension steel characteristic resistance:	[kN]	18.7
γ_{Ms}	Partial safety factor: ^{*)}	[-]	1.5
Tension loads: pull-out failure in concrete			
$N_{Rk,p, ucr}$	Tension characteristic resistance in C20/25 uncracked concrete:	[kN]	9
$\psi_{c, ucr}$	C30/37	[-]	1.22
$\psi_{c, ucr}$	C40/45	[-]	1.41
$\psi_{c, ucr}$	C50/60	[-]	1.58
$N_{Rk,p, cr}$	Tension characteristic resistance in C20/25 cracked concrete:	[kN]	6
$\psi_{c, cr}$	C30/37	[-]	1.22
$\psi_{c, cr}$	C40/45	[-]	1.41
$\psi_{c, cr}$	C50/60	[-]	1.58
γ_{inst}	Installation safety factor: ^{*)}	[-]	1.2
Tension loads: concrete cone and splitting failure			
h_{ef}	Effective embedment depth:	[mm]	42
γ_{ins}	Installation safety factor: ^{*)}	[-]	1.2
$s_{cr,N}$	Critical spacing:	[mm]	126
$c_{cr,N}$	Critical edge distance:	[mm]	63
$s_{cr,sp}$	Critical spacing (splitting):	[mm]	126
$c_{cr,sp}$	Critical edge distance (splitting):	[mm]	63

^{*)} In absence of other national regulations

Table C2: Displacements under tension loads for CLR 6

Displacements under tension loads in uncracked concrete			Performance
			CLR6
N	Service tension load in uncracked concrete C20/25 to C50/60:	[kN]	3.6
δ_{N0}	Short term displacement under tension loads:	[mm]	0.4
$\delta_{N\infty}$	Long term displacement under tension loads:	[mm]	1.0
Displacements under tension loads in cracked concrete			Performance
			CLR6
N	Service tension load in cracked concrete C20/25 to C50/60:	[kN]	2.4
δ_{N0}	Short term displacement under tension loads:	[mm]	0.6
$\delta_{N\infty}$	Long term displacement under tension loads:	[mm]	1.4

CLR 6

Performances
Characteristic values for tension loads
Displacement under tension loads

Annex C1

Table C3: Characteristic values to shear loads of design method A

Characteristic values of resistance to shear loads of design method A			Performance
			CLR6
Shear loads: steel failure without lever arm			
$V_{Rk,s}$	Shear steel characteristic resistance:	[kN]	7.5
γ_{Ms}	Partial safety factor: *)	[-]	1.25
Shear loads: steel failure with lever arm			
$M^0_{Rk,s}$	Characteristic bending moment:	[Nm]	15.2
γ_{Ms}	Partial safety factor: *)	[-]	1.25
Shear loads: concrete pryout failure			
K	K factor:	[-]	1
γ_{inst}	Installation safety factor: *)	[-]	1
Shear loads: concrete edge failure			
l_f	Effective anchorage depth under shear loads:	[mm]	42
d_{nom}	Outside anchor diameter:	[mm]	7.5
γ_{inst}	Installation safety factor: *)	[-]	1

*) In absence of other national regulations

Table C4: Displacements under shear loads

Displacements under shear loads			Performance
			CLR6
V	Service shear load in cracked and uncracked concrete C20/25 to C50/60:	[kN]	3.0
δ_{V0}	Short term displacement under shear loads:	[mm]	1.3
$\delta_{V\infty}$	Long term displacement under shear loads:	[mm]	2.0

Information for design of anchorages under shear loads:

In general the conditions given in EN 1992-4:2018 are not fulfilled because the diameter of the clearance hole in the fixture (see "Installation parameters" table B1) is greater than the values given in table 6.1 for the corresponding diameter of the anchor. For anchors groups with $n > 1$ the characteristic load resistance $V^g_{Rk,s}$ should be limited to $\max 2 V_{Rk,s}$

However for each specific anchor length the manufacturer may specify the thickness of fixture for which these conditions are fulfilled.

CLR 6	Annex C2
Performances Characteristic values for shear loads Displacements under shear loads	

Table D1: Characteristic values to fire resistance

Fire resistance duration = 30 minutes			CLR6
Tension loads, steel failure			
$N_{Rk,s,fi,30}$	Characteristic resistance	[kN]	0.23
Pull-out failure			
$N_{Rk,p,fi,30}$	Character. resistance in concrete C20/25 to C50/60	[kN]	1.50
Concrete cone failure **)			
$N_{Rk,c,fi,30}$	Character. resistance in concrete C20/25 to C50/60	[kN]	2.06
Shear loads steel failure without lever arm			
$V_{Rk,s,fi,30}$	Characteristic resistance	[kN]	0.23
Shear loads, steel failure with lever arm			
$M_{Rk,s,fi,60}$	Characteristic bending resistance	[Nm]	0.19

Fire resistance duration = 60 minutes			CLR6
Tension loads, steel failure			
$N_{Rk,s,fi,60}$	Characteristic resistance	[kN]	0.21
Pull-out failure			
$N_{Rk,p,fi,60}$	Character. resistance in concrete C20/25 to C50/60	[kN]	1.50
Concrete cone failure **)			
$N_{Rk,c,fi,60}$	Character. resistance in concrete C20/25 to C50/60	[kN]	2.06
Shear loads, steel failure without lever arm			
$V_{Rk,s,fi,60}$	Characteristic resistance	[kN]	0.21
Shear loads, steel failure with lever arm			
$M_{Rk,s,fi,60}$	Characteristic bending resistance	[Nm]	0.17

Fire resistance duration = 90 minutes			CLR6
Tension loads, steel failure			
$N_{Rk,s,fi,90}$	Characteristic resistance	[kN]	0.16
Pull-out failure			
$N_{Rk,p,fi,90}$	Character. resistance in concrete C20/25 to C50/60	[kN]	1.50
Concrete cone failure **)			
$N_{Rk,c,fi,90}$	Character. resistance in concrete C20/25 to C50/60	[kN]	2.06
Shear loads, steel failure without lever arm			
$V_{Rk,s,fi,90}$	Characteristic resistance	[kN]	0.16
Shear loads, steel failure with lever arm			
$M_{Rk,s,fi,90}$	Characteristic bending resistance	[Nm]	0.13

CLR 6

Performances
Characteristic values for fire resistance

Annex D1

English translation prepared by IETcc

Fire resistance duration = 120 minutes			CLR6
Tension loads, steel failure			
$N_{Rk,s,fi,120}$	Characteristic resistance	[kN]	0.12
Pull-out failure			
$N_{Rk,p,fi,120}$	Character. resistance in concrete C20/25 to C50/60	[kN]	1,20
Concrete cone failure **)			
$N_{Rk,c,fi,120}$	Character. resistance in concrete C20/25 to C50/60	[kN]	1.65
Shear loads, steel failure without lever arm			
$V_{Rk,s,fi,120}$	Characteristic resistance	[kN]	0.12
Shear loads, steel failure with lever arm			
$M_{Rk,s,fi,120}$	Characteristic bending resistance	[Nm]	0.10

Spacing and edge distances			CLR6
$S_{cr,N}$	Spacing	[mm]	168
S_{min}	Minimum spacing	[mm]	45
$C_{cr,N}$	Edge distance	[mm]	84
C_{min}	Minimum edge distance (one side fire)	[mm]	84
C_{min}	Minimum edge distance (two sides fire)	[mm]	300
γ_{Msp}	Partial safety factor ^{*)}	[-]	1.0

*) In absence of other national regulations

**) As a rule, splitting failure can be neglected when cracked concrete and reinforcement is assumed.

Concrete pry-out failure			CLR6
k factor		[-]	1
According EN 1992-4:2018, these values of k factor and the relevant values of $N_{Rk,c,fi}$ given in the above tables have to be considered in the design.			

Concrete edge failure

The characteristic resistance $V_{Rk,c,fi}^0$ in C20/25 to C50/60 concrete is determined by:

$V_{Rk,c,fi}^0 = 0.25 \times V_{Rk,c}^0$ ($\leq R90$) and $V_{Rk,c,fi}^0 = 0.20 \times V_{Rk,c}^0$ (R120)

With $V_{Rk,c}^0$ initial value of the characteristic resistance in cracked concrete C20/25 under normal temperature according to EN 1992-4:2018.

CLR 6

Performances
Characteristic values for fire resistance

Annex D2